

Mobile Network Security

Mobile Security 2026

Florian Draschbacher
florian.draschbacher@tugraz.at

Outline

- Background
 - Evolution of cellular networks
 - Architecture
 - Security
- Attacks
 - Active, Passive
 - Built-in backdoors
- Protection Mechanisms
 - Are you protected? How to defend yourself?

Introduction

- So far we concentrated on the **smarts** of smartphones
 - What about the phone part?
- How do phone calls, messaging and Internet over cellular networks work?
 - What components are involved?
 - What protocols and technologies do they use?
- What about the security of these technologies?
 - Who can intercept communication?
 - What are the privacy consequences of being reachable on-the-go?
 - ...



MOBILE & WIRELESS

02 Service Vulnerability Exposed User Location

A vulnerability in O2's implementation of the IMS standard resulted in user location data being exposed in network responses.



By [Ionut Arghire](#) | May 20, 2025 (6:02 AM ET)



A vulnerability in 4G Calling, a Voice over LTE (VoLTE) service launched recently by UK telecom giant O2, resulted in user location information being leaked in network responses.

Based on the IP Multimedia Subsystem (IMS) standard, VoLTE allows users to make voice calls and send text messages over 4G/LTE and newer mobile networks at higher speeds compared to those offered by older 3G/2G networks.

It works by delivering the voice service as data flows, but requires that the device, firmware, and mobile network support the technology.

Looking to test the quality of O2's newly launched 4G Calling service, UK network enthusiast [Daniel Williams](#) discovered that messages his phone received from the network contained a lot of information, including details on the user's location.

What?

Misconfigured network leaked user location

Problems?

- Mobile networks are incredibly complex systems
- They process a lot of sensitive user data
 - Communication:
 - Calls, Messages, Internet traffic, ...
 - Metadata:
 - Who contacts whom
 - Nearest cell phone towers

Introduction

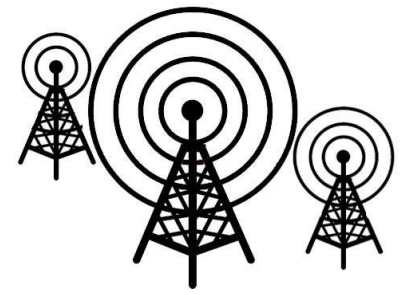

Goals

- Protect business models and operational services
- Privacy for user identity, data confidentiality
- Regulatory issues → legal interception

How to apply security?

- Minimize number of security threats
- Remember: Cost efficiency & high performance (load balancing)
- Interoperability with legacy systems (GSM <-> UMTS <-> LTE)
- Practical issues, e.g. end-to-end vs. hop-by-hop security?



Introduction

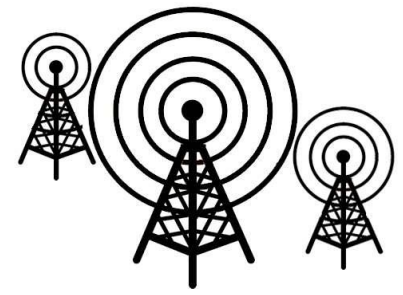

Technical objectives

- Authentication of user and network
 - Confidentiality
 - Communication data & signaling data
 - User & device identity
 - User location
 - Signaling data integrity
 - User untraceability(?)
- Need strong algorithms for encryption and integrity checking,
→ Need algorithm extensibility for future-proofness



**Mobile Equipment
(= Mobile Network Client)**

Mobile Equipment Architecture

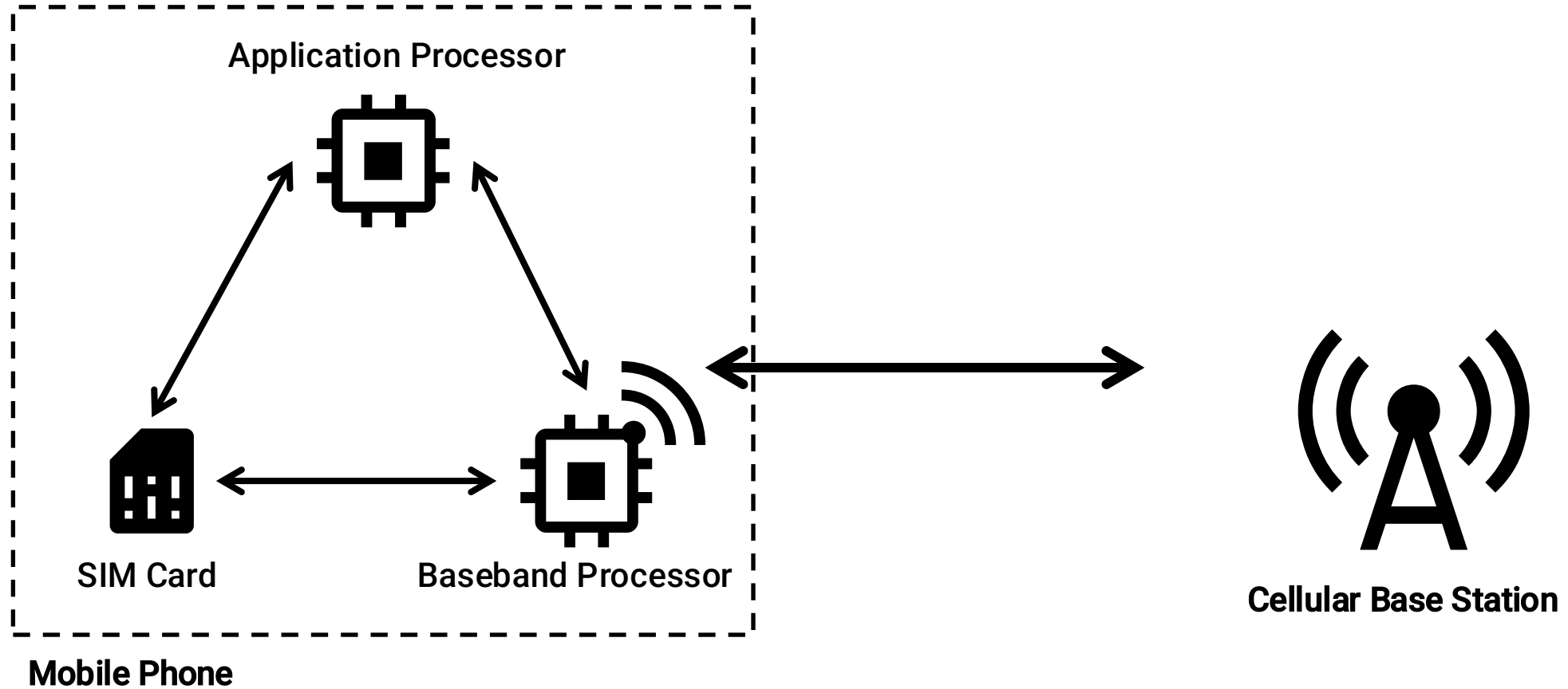

Subscriber Identification Module (SIM) Card

aka. “Universal Integrated Circuit Card (UICC)”

- A smart card, containing microcontroller and (flash) memory
- Authenticates a client in the cellular network
 - Symmetric authentication key K_i
- Contains unique identifiers
 - IMSI: International Mobile Subscriber Identifier
 - ICCID: Integrated Circuit Card Identifier
- Also: Java programs, contacts, preferred roaming networks, ...

Source: [wikipedia.org](https://en.wikipedia.org) / Janke / CC BY-SA

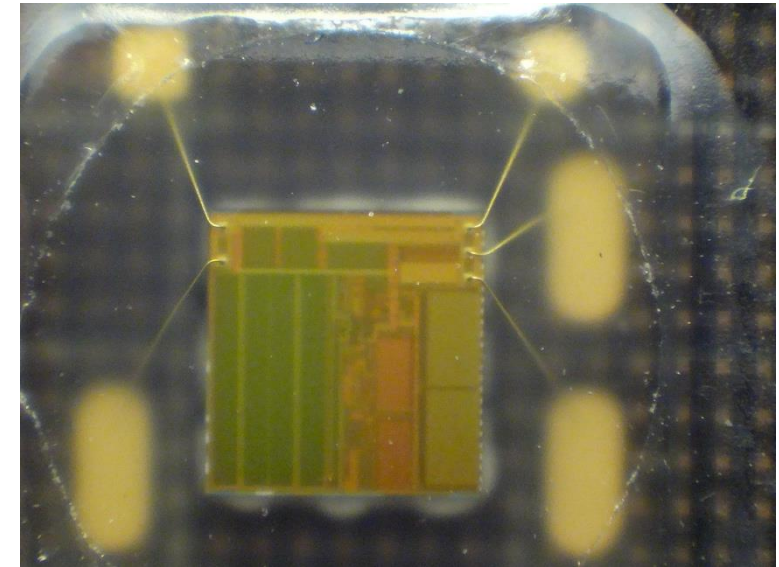

SIM Communication with Mobile Equipment

- ISO-standardised protocol commonly referred to as APDU
 - Application Protocol Data Unit
- May be intercepted using special hardware and software tools

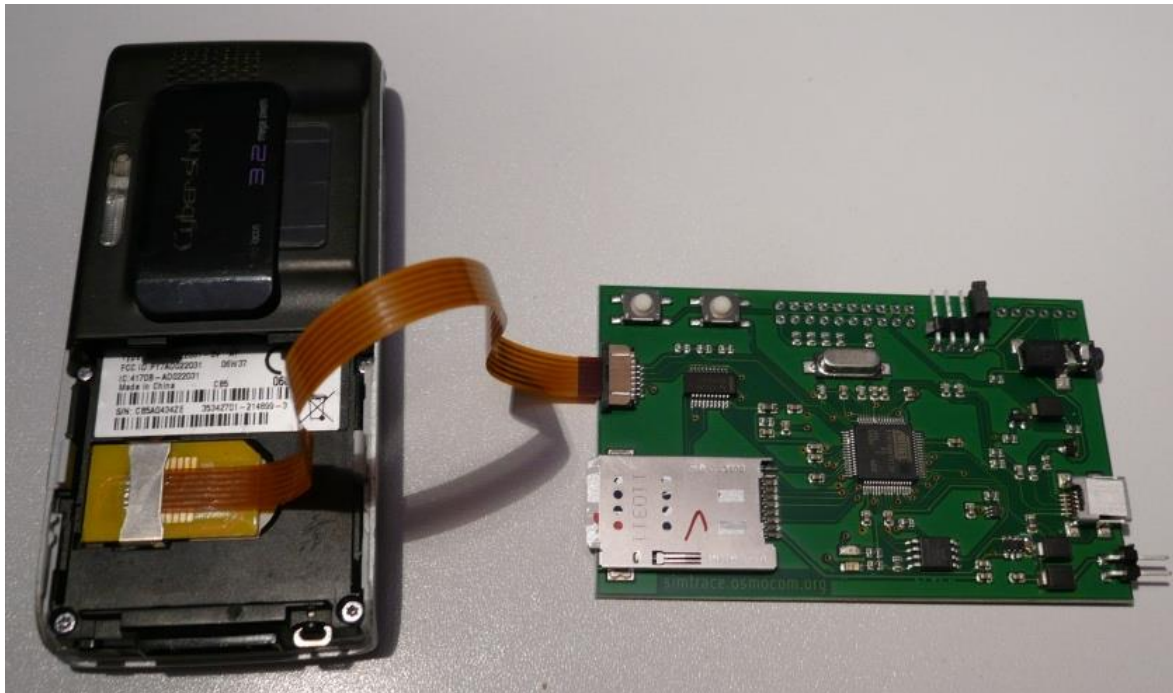

Source: osmocom.org

```
gsm_sim
No. Time Source Destination Protocol Length Info
362 45.6... 127... 127.0.0.1 GSM SIM 65 ISO/IEC 7816-4 VERIFY CHV CHV=1 : 63c3
363 45.6... 127... 127.0.0.1 GSM SIM 65 ISO/IEC 7816-4 VERIFY CHV CHV=129 : 63c3
364 45.6... 127... 127.0.0.1 GSM SIM 65 ISO/IEC 7816-4 UNBLOCK CHV CHV=1 : 63ca
365 45.6... 127... 127.0.0.1 GSM SIM 65 ISO/IEC 7816-4 UNBLOCK CHV CHV=129 : 63ca
366 45.6... 127... 127.0.0.1 GSM SIM 67 ISO/IEC 7816-4 SELECT File EF.SST
367 45.6... 127... 127.0.0.1 GSM SIM 90 ISO/IEC 7816-4 GET RESPONSE
368 45.6... 127... 127.0.0.1 GSM SIM 77 ISO/IEC 7816-4 READ BINARY Offset=0
369 45.6... 127... 127.0.0.1 GSM SIM 67 ISO/IEC 7816-4 SELECT File EF.EST
370 45.6... 127... 127.0.0.1 GSM SIM 90 ISO/IEC 7816-4 GET RESPONSE
371 45.6... 127... 127.0.0.1 GSM SIM 68 ISO/IEC 7816-4 READ BINARY Offset=0
372 45.6... 127... 127.0.0.1 GSM SIM 67 ISO/IEC 7816-4 SELECT File EF.IMSI
373 45.9... 127... 127.0.0.1 GSM SIM 98 ISO/IEC 7816-4 GET RESPONSE
374 45.9... 127... 127.0.0.1 GSM SIM 74 ISO/IEC 7816-4 READ BINARY Offset=0
375 45.9... 127... 127.0.0.1 GSM SIM 67 ISO/IEC 7816-4 SELECT File EF.DCK : Wrong parameters: File not found
376 45.9... 127... 127.0.0.1 GSM SIM 69 ISO/IEC 7816-4 SELECT /ADF/EF.IMSI
377 45.9... 127... 127.0.0.1 GSM SIM 98 ISO/IEC 7816-4 GET RESPONSE
378 45.9... 127... 127.0.0.1 GSM SIM 69 ISO/IEC 7816-4 SELECT /ADF/EF.CNL : Wrong parameters: File not found
379 45.9... 127... 127.0.0.1 GSM SIM 69 ISO/IEC 7816-4 SELECT /ADF/EF.MSISDN
380 45.9... 127... 127.0.0.1 GSM SIM 92 ISO/IEC 7816-4 GET RESPONSE

▶ Frame 496: 71 bytes on wire (568 bits), 71 bytes captured (568 bits) on interface 0
▶ Ethernet II, Src: 00:00:00_00:00:00 (00:00:00:00:00:00), Dst: 00:00:00_00:00:00 (00:00:00:00:00:00)
▶ Internet Protocol Version 4, Src: 127.0.0.1, Dst: 127.0.0.1
▶ User Datagram Protocol, Src Port: 35137, Dst Port: 4729
▶ GSM SIM 11.11

0000 00 00 00 00 00 00 00 00 00 00 08 00 45 00 .....E.
0010 00 39 25 f0 40 00 40 11 16 c2 7f 00 00 01 7f 00 .9%.@. .B.
0020 00 01 89 41 12 79 00 25 fe 38 02 04 04 00 00 00 ...A.y.% .B.
0030 00 00 00 00 00 00 00 00 00 00 00 a4 08 04 06 7f .....
0040 10 5f 3a 4f 3a 61 24 ...:a$

wireshark lo 20180424173458 AudwO Packets: 534 · Displayed: 286 (53.6%) Profile: Default
```

Source: [Screenshot LiveOverflow](https://www.screenshotliveoverflow.com)

gsm_sim Expression...

No.	Time	Source	Destination	Protocol	Length	Info
362	45.6...	127....	127.0.0.1	GSM SIM	65	ISO/IEC 7816-4 VERIFY CHV CHV=1 : 63c3
363	45.6...	127....	127.0.0.1	GSM SIM	65	ISO/IEC 7816-4 VERIFY CHV CHV=129 : 63c3
364	45.6...	127....	127.0.0.1	GSM SIM	65	ISO/IEC 7816-4 UNBLOCK CHV CHV=1 : 63ca
365	45.6...	127....	127.0.0.1	GSM SIM	65	ISO/IEC 7816-4 UNBLOCK CHV CHV=129 : 63ca
366	45.6...	127....	127.0.0.1	GSM SIM	67	ISO/IEC 7816-4 SELECT File EF.SST
367	45.6...	127....	127.0.0.1	GSM SIM	90	ISO/IEC 7816-4 GET RESPONSE
368	45.6...	127....	127.0.0.1	GSM SIM	77	ISO/IEC 7816-4 READ BINARY Offset=0
369	45.6...	127....	127.0.0.1	GSM SIM	67	ISO/IEC 7816-4 SELECT File EF.EST
370	45.6...	127....	127.0.0.1	GSM SIM	90	ISO/IEC 7816-4 GET RESPONSE
371	45.6...	127....	127.0.0.1	GSM SIM	68	ISO/IEC 7816-4 READ BINARY Offset=0
372	45.6...	127....	127.0.0.1	GSM SIM	67	ISO/IEC 7816-4 SELECT File EF.IMSI
373	45.9...	127....	127.0.0.1	GSM SIM	98	ISO/IEC 7816-4 GET RESPONSE
374	45.9...	127....	127.0.0.1	GSM SIM	74	ISO/IEC 7816-4 READ BINARY Offset=0
375	45.9...	127....	127.0.0.1	GSM SIM	67	ISO/IEC 7816-4 SELECT File EF.DCK : Wrong parameters: File not found
376	45.9...	127....	127.0.0.1	GSM SIM	69	ISO/IEC 7816-4 SELECT /ADF/EF.IMSI
377	45.9...	127....	127.0.0.1	GSM SIM	98	ISO/IEC 7816-4 GET RESPONSE
378	45.9...	127....	127.0.0.1	GSM SIM	69	ISO/IEC 7816-4 SELECT /ADF/EF.CNL : Wrong parameters: File not found
379	45.9...	127....	127.0.0.1	GSM SIM	69	ISO/IEC 7816-4 SELECT /ADF/EF.MSISDN
380	45.9...	127....	127.0.0.1	GSM SIM	92	ISO/IEC 7816-4 GET RESPONSE

▶ Frame 496: 71 bytes on wire (568 bits), 71 bytes captured (568 bits) on interface 0

▶ Ethernet II, Src: 00:00:00_00:00:00 (00:00:00:00:00:00), Dst: 00:00:00_00:00:00 (00:00:00:00:00:00)

▶ Internet Protocol Version 4, Src: 127.0.0.1, Dst: 127.0.0.1

▶ User Datagram Protocol, Src Port: 35137, Dst Port: 4729

▶ GSM SIM 11.11

```

0000  00 00 00 00 00 00 00 00 00 00 00 08 00 45 00  .....E.
0010  00 39 25 f0 40 00 40 11 16 c2 7f 00 00 01 7f 00  .9%.@.@. ....
0020  00 01 89 41 12 79 00 25 fe 38 02 04 04 00 00 00  ...A.y.% .8.....
0030  00 00 00 00 00 00 00 00 00 00 00 a4 08 04 06 7f  .....
0040  10 5f 3a 4f 3a 61 24  ....._:0:a$

```

wireshark lo_20180424173458_AaudwO Packets: 534 · Displayed: 286 (53.6%) Profile: Default

Card Holder Verification = PIN Code

Read IMSI

Authentication Process (for 2G)

- The K_i in SIM card is issued by network operator, stored in their database
1. Mobile Equipment (ME) passes PIN to SIM card to get IMSI
 2. ME passes IMSI to network operator
 3. Network operator generates random nonce RAND
 4. Network operator computes $SRES_1 = A3_{K_i}(RAND)$ and $K_C = A8_{K_i}(RAND)$
 5. Network operator sends RAND to ME
 6. ME passes RAND to SIM card, which computes $SRES_2$ and K_C
 7. ME sends $SRES_2$ to network operator
 8. If $SRES_1$ equals $SRES_2$, the authentication succeeded
 9. Subsequent communication will be encrypted using K_C

SIM Cloning

- The authentication process was designed so that K_i never leaves the SIM card
 - Legitimate SIM card required to access mobile network
- However, the COMP128 implementation of the A3/A8 functions is vulnerable
 - Designed in secrecy, but reverse-engineered in 1998, attacks soon after
- K_i could be calculated from a series of A3/A8 challenges to SIM card
 - 20k challenges (brute force: 2^{128})
- K_i and IMSI can be written into blank SIM cards to create SIM clone
- Modern mobile networks use improved COMP128, SIMs limit challenges

SIM Cloning

- Cloned SIMs can authenticate to the network as the legitimate SIM card
 - Intercept or inject communication on behalf of original SIM holder
- Extraction from SIM cards is not the only way to obtain K_i
 - Access network operator database
 - Infiltrate SIM card manufacturer

The NSA Reportedly Stole Millions Of SIM Encryption Keys To Gather Private Data

Alex Wilhelm, Sarah Buhr

/ 2:39 AM GMT+1 • February 20, 2015



The American National Security Agency (NSA), and the British Government Communications Headquarters (GCHQ), similar clandestine intelligence agencies, stole SIM card encryption keys from a manufacturer, allowing the groups to decrypt global cellular communications data.

Embedded SIM (eSIM)

- Originally, SIM was the term for the hardware (card) and its software
- 3G and later denoted the card as Universal Integrated Circuit Card (UICC)
 - Running USIM (3G+) and SIM (2G) applications
- Further abstraction: Embedded SIM
 - eUICC: Chip statically mounted to Mobile Equipment
 - Carrier profiles installed onto eUICC contain USIM, SIM applications
- Every eUICC is uniquely identified using eSIM ID (EID)
- Carrier profiles are provisioned encrypted
 - May only be decrypted inside eUICC

SIM Swap Attacks / SIM Jacking

- A mobile numbers is not fixed to a SIM card
 - Mobile Number Portability (MNP) enables carrier migration
 - Exact process varies by country

Can be abused by attackers to gain control over a mobile number:

1. Collect personal information about victim
 2. Initiate number migration to attacker's SIM through victim's carrier
 3. Prove identity through stolen personal information
 4. After migration, the victim loses control over the mobile number
- SMS is still commonly used for Two Factor Authentication!
 - This attack has been used for high-profile hacks and is on the rise!

Mobile Phone Networks

Modern Mobile Phone Networks

- Distributed over land areas called „cells“
 - “Cellular network”
- Every cell is covered by ≥ 1 base stations
 - More depending on needed capacity
- Cells use different radio frequencies
 - Prevents interference of neighbouring cells
- Base stations are interconnected in multiple layers
 - And linked to landline network and Internet

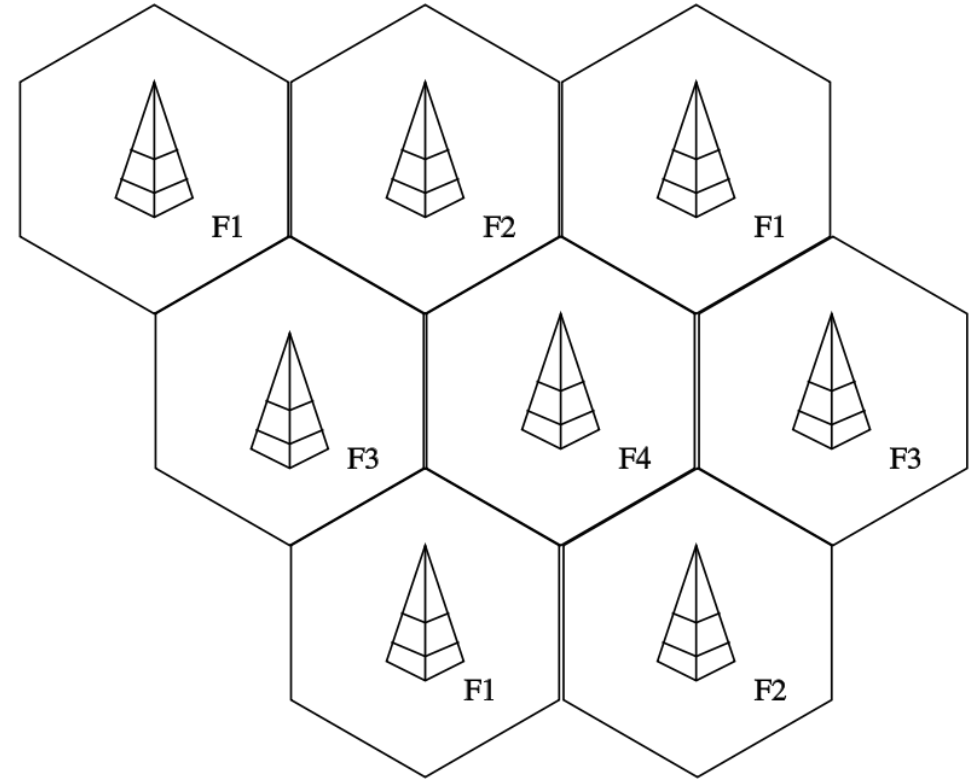

Image: [Andrew Pmk / CC-BY-SA](#)

Cellular Network Generations

- Cellular Network technology is constantly advancing
- New technology generations are rolled out roughly every 10 years
 - First generation: 1980s
 - Currently: Roll-out of 5G in progress (Austria: Mostly 5G Non-Standalone)
 - 6G anticipated for 2030
- Generation: ~"Improved technology that is incompatible with previous one"
 - Still: Mobile Equipment is usually backwards-compatible
- The exact technology used for a generation depends on the region!
 - E.g. 3G in America (CDMA2000) is incompatible with 3G (UMTS) in Europe

General Network Structure

- A network consists of functionality in multiple subsystems
 - Base Station Subsystem (BSS): Base stations for radio link
 - Core Network / Network Switching Subsystem: Managing calls
 - Data Core Network (eg. GPRS Core Network): Managing data transfers
- The radio link determines the physical data transfer protocol
 - Typically changes between different generations of cellular networks
- Rest of the infrastructure helps locate phones
 - Establishing calls, delivering data, ... despite phone moving between cells
 - May be shared between different network generations

Cellular Network Technologies (Europe)

- **1. Generation:**
 - Analog audio transmission
 - Data only through a modem (modulator-demodulator)
- **2. Generation:** GSM
 - Encrypted digital audio between phone and base station
 - Later added GPRS and EDGE for packet-switched data communications
- **3. Generation to 5. Generation:** UMTS, LTE, 5G
 - Faster data communications
 - Improved bandwidth

2G Networks

- Commercial launch in 1992
- Only authentication of ME towards network
- TDMA-based, circuit switching
 - „Time Division Multiple Access“
 - Share same frequency channel for multiple users by dividing signal into different time slots

Versions

- 2.5G: GPRS (added in 2000)
 - Theoretical speed: 171 kbps down, 40 kbps up
- 2.7G: EDGE
 - Theoretical speed: 384 kbps down, 108 kbps up

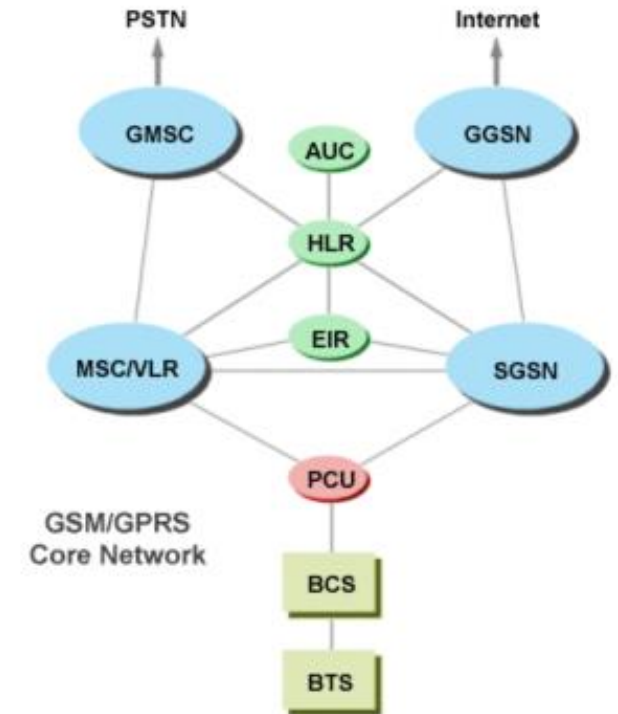

3G Networks

Features

- Same core network as 2G: Circuit-switched (GSM) & packet-switched (UMTS)
- Mutual authentication between base station & mobiles
- Downgrade attacks still possible (e.g. before authentication completed)

Versions

- 3G UMTS max. 2 Mbps down, 384 kbps up
- 3.5G HSDPA max. 14.4 Mbps down, 2 Mbps up
- 3.6G HSUPA max. 14.4 Mbps down, 5.76 Mbps up
- 3.75G HSPA+ max. 21 Mbps down, 5.8 Mbps up
- 3.8G HSPA+ Enhanced max. 84 Mbps down, 20 Mbps up
- 3.9G LTE (**pre 4G!**) max. 100 Mbps down, 50 Mbps up

Authentication and Key Agreement (AKA; 3G+)

- SIM stores unique K and per-operator OP (or K and $OP_c = OP \oplus AES_K(OP)$)
 - Additionally: Sequence Number SQN for preventing replay attacks
1. Initial steps as for 2G
 2. Network operator computes
AUTN = $F1_{K+OP}(RAND, SQN)$, **XRES** = $F2_{K+OP}(RAND)$, **CK** = $F3_{K+OP}(RAND)$, ...
 3. Sends $RAND$ and **AUTN** to ME, which passes it to USIM
 4. USIM checks **AUTN** using its own values of K and SQN
 5. ME calculates **RES** = $F2_{K+OP}(RAND)$, **CK** = $F3_{K+OP}(RAND)$, sends **RES** to network
 6. If **XRES** equals **RES**, the authentication succeeded
 7. Subsequent communication will be encrypted using **CK**
- Not shown: Additional keys for packet integrity, obfuscating SQN

Evolution: 4G Networks

Currently: **LTE Advanced (LTE-A)**

max. 1 Gbits down, 500 Mbits up

Features

- Only IP-based communication (also voice → VoLTE), no more circuit switching
 - Fallback support for circuit-switched calls
- IMSI still occasionally sent in clear
- New algorithms and extensibility
 - Word-oriented stream cipher (128 bit key): SNOW 3G
 - Integrity, confidentiality: AES-GCM



3G/4G Network Structure

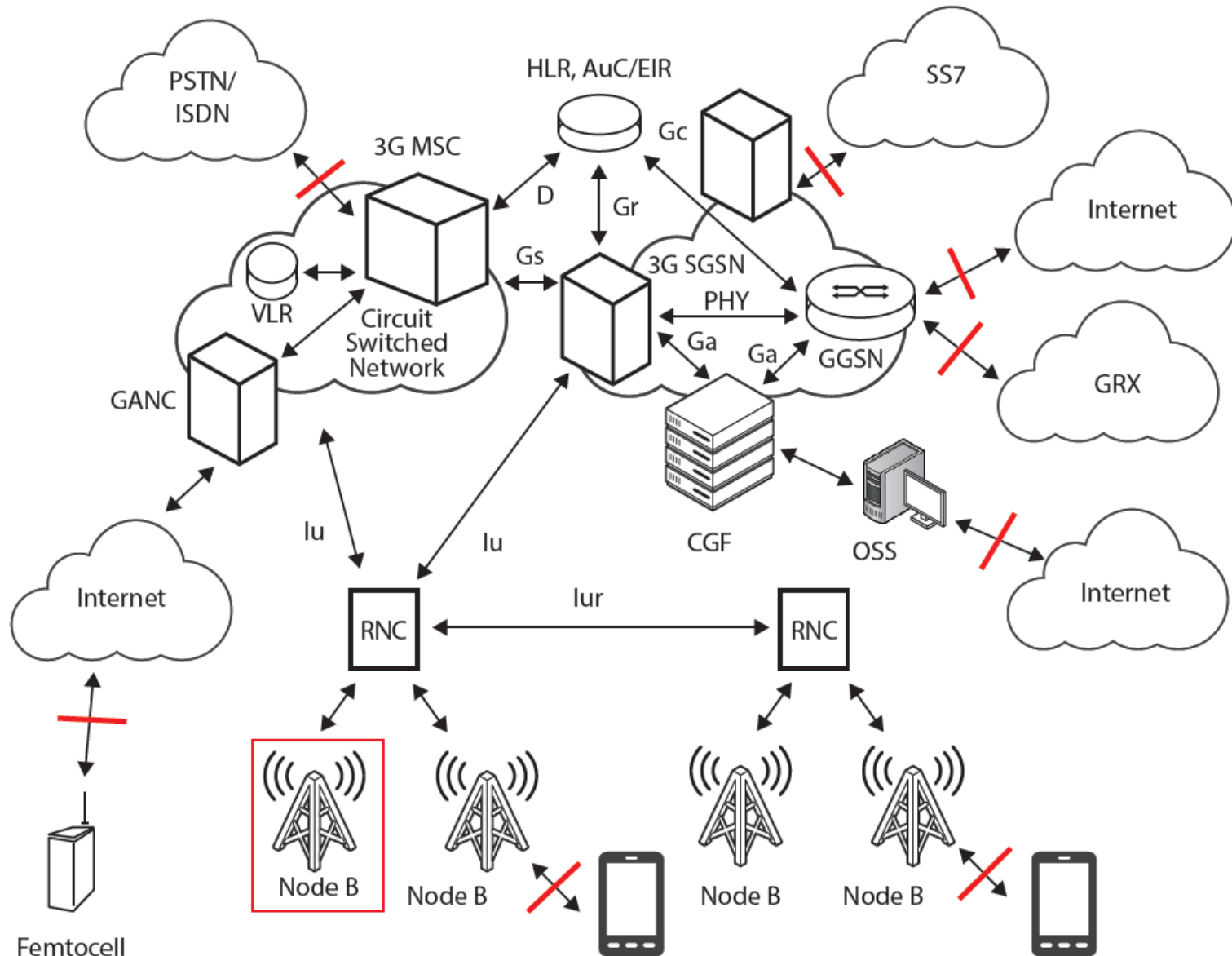

Legend

- Node B
- UMTS Base Station
- RNC
- Radio Network Controller
- SGSN
- Serving GPRS Support Node
- GGSN
- Gateway GPRS Support Node
- MSC
- Mobile Switching Center

3G/4G Network Workflow

1) Node B

- Minimum functionality base station in UMTS networks
- Typically located near the antenna (but not necessarily)
- Controlled by RNC using a „Iub“ interface

GSM equivalent: Base Transceiver Station (BTS)

2) RNC

- Main task: Manage connected Node Bs and radio resources
 - Channels, signal strength (power), cell handover
- Can build Mesh networks with other RNCs

3a) Speech: MSC (Mobile Switching Centre) → routing voice / SMS

3b) Data: SGSN → routing data

3G/4G Network Components

SGSN

- Data delivery from/to mobile station in defined geographical service area
- (De-)tunnel packets from/to GGSN (*Downlink*, Uplink)
- Handover → phone moves from **Routing Area A** to **Routing area B**
- User data billing

GGSN

- Inter-networking between internal network and external packet switched networks (Internet)
- Keeps your connections alive while moving around
- User authentication, IP pool management, QoS



5G Networks

5G Standalone (SA)

max. 20 Gbits down, 10 Gbits up

5G Non-Standalone (NSA)

~max. 10 Gbits down, 3 Gbits up

(NSA \approx LTE Core Network with 5G radio)

Features

- New radio link: **New Radio** air interface: higher throughput, reduced latency
- Improved privacy: Permanent identifiers such as IMSI never sent in plain
 - Subscription Concealed Identifier (SUCI)
 - ME encrypts 5G IMSI using home network public key
 - No longer allows catching IMSI prior to authentication
- Integrity protection for user plane (not just control plane)
 - Covers actual user data

GSM Encryption

How? Proprietary stream ciphers to encrypt traffic on air interface



Set of algorithms

- A5/0: Unencrypted, no cracking needed 😊
 - broken by design (and banned by many carriers)
- A5/1: Combination of 3 linear feedback shift registers (LFSRs)
 - 64-bit key, broken using rainbow tables in 2009
- A5/2: export version of A5/1
 - broken in 1999, banned since 2006
- A5/3 + A5/4: Backport of Kasumi UMTS cipher (current standard)
 - 64/128-bit key, 64-bit input / output

GSM Encryption A5/1

Key size: 64 bits (!!)
(Even only 54 effective bits in
early versions of A3/A8 key
generation)

Avoid replay attacks

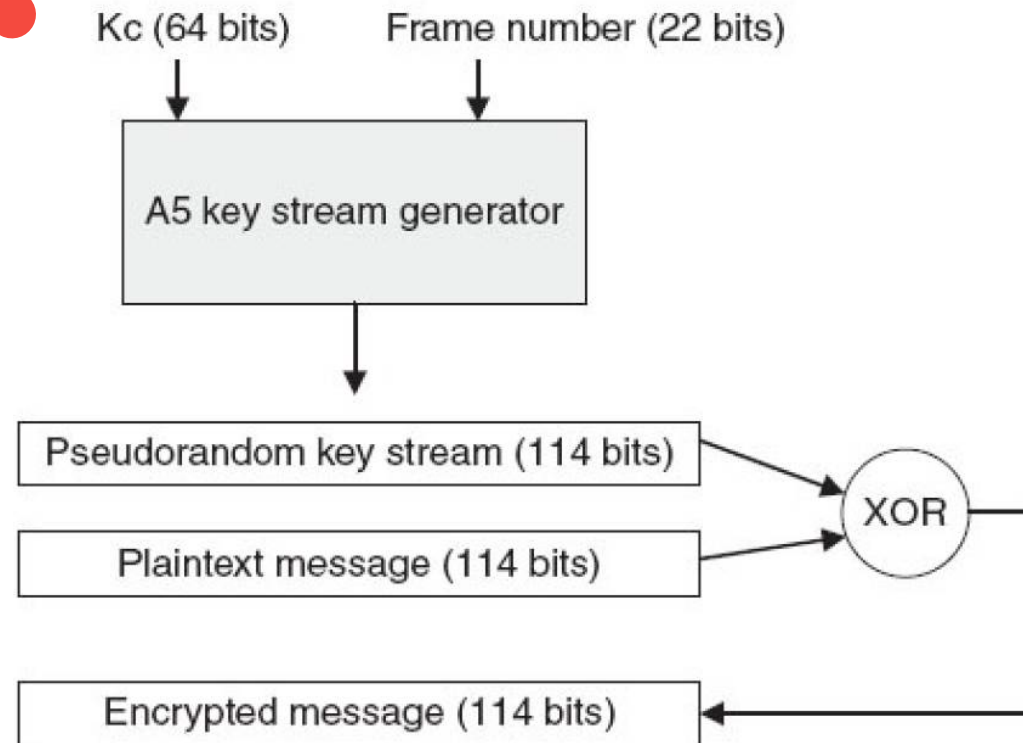

(Recent) Attacks

Scenarios

Intercept

- Adversary records calls & SMS
 - Decryption in real time or offline batch process (after recording)

Impersonation

- Calls or SMS spoofed
- Received using stolen mobile identity

Tracking

- Tracing mobile subscribers

Scenarios & Mitigations

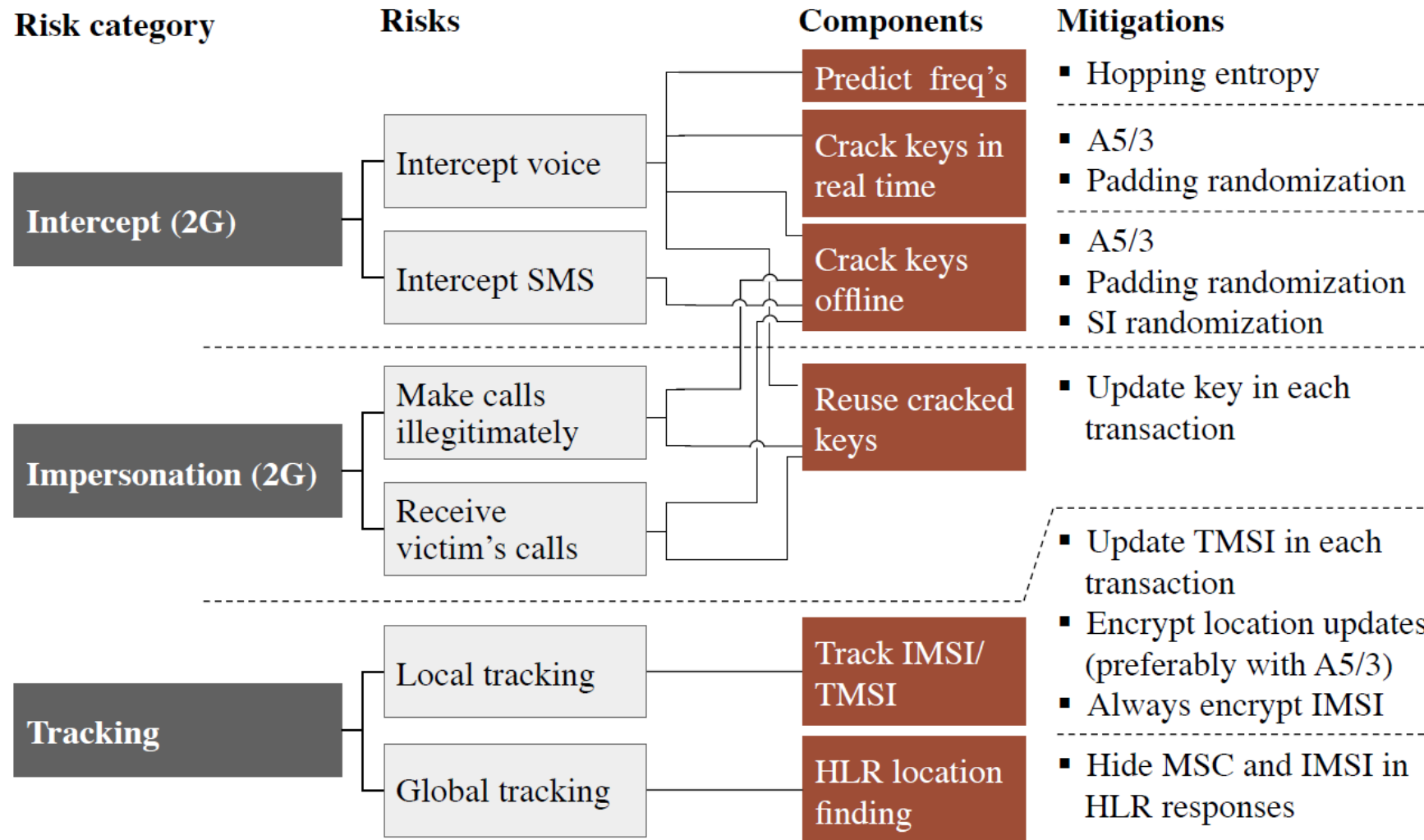

Source: <https://goo.gl/15pRhE>

Active Attack: Fake Base Stations

= IMSI Catchers

- Partially exploit weaknesses in GSM & 3G networks
- Used for
 - Tracking users (IMEI, IMSI, location)
 - Eavesdropping calls, data, SMS, etc.
 - Man-in-the-Middle
 - Attack phone using operator system messages,
 - e.g. Management Interface, re-program APN, HTTP proxy, SMS/WAP server, ...
 - Attack SIM or phone baseband
 - Geo-targeting ads (SMS)



Tracking,
Call & Data interception

How does it work?

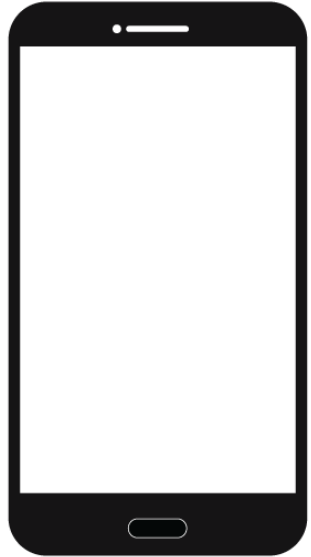

← Advertise base station on beacon channel

→ Phone sends IMSI / TMSI (sort of secret)

← MCC: Mobile Country Code (232 for .at)

MNC: Mobile Network Code

- Country-specific tuple with MCC, e.g. 232-01 for a1.net

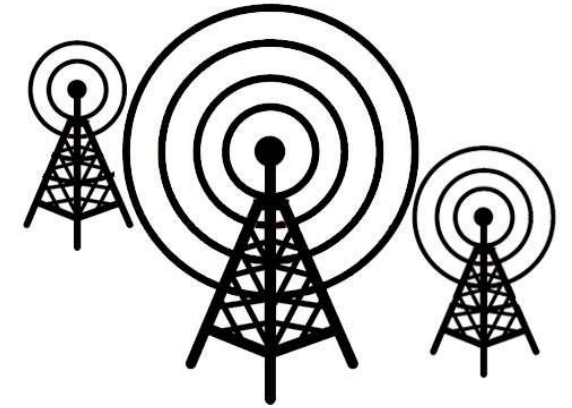

→ Phones will connect to *any* base station with spoofed MNC/MCC

- If you claim it, they will come because strongest signal wins 😊

```
Terminal 1
Fichier  Édition  Affichage  Rechercher  Terminal  Aide
$ sudo python simple_IMSI-catcher.py
WARNING: No route found for IPv6 destination :: (no default route?)
cpt ; IMSI ; country ; brand ; operator
1 ; 234 20 730143 ; Guernsey (United Kingdom) ; 3 ; Hutchison 3G UK Ltd
2 ; 208 20 154308 ; France ; Bouygues ; Bouygues Telecom
3 ; 208 20 029666 ; France ; Bouygues ; Bouygues Telecom
4 ; 208 20 085162 ; France ; Bouygues ; Bouygues Telecom
5 ; 208 20 031381 ; France ; Bouygues ; Bouygues Telecom
6 ; 208 20 031233 ; France ; Bouygues ; Bouygues Telecom
7 ; 208 20 031343 ; France ; Bouygues ; Bouygues Telecom
8 ; 208 20 171286 ; France ; Bouygues ; Bouygues Telecom
9 ; 208 20 090096 ; France ; Bouygues ; Bouygues Telecom
10 ; 208 20 100817 ; France ; Bouygues ; Bouygues Telecom
11 ; 208 20 144546 ; France ; Bouygues ; Bouygues Telecom
12 ; 208 20 220088 ; France ; Bouygues ; Bouygues Telecom
13 ; 208 20 171268 ; France ; Bouygues ; Bouygues Telecom
14 ; 208 20 154457 ; France ; Bouygues ; Bouygues Telecom
15 ; 208 20 144758 ; France ; Bouygues ; Bouygues Telecom
16 ; 208 20 031231 ; France ; Bouygues ; Bouygues Telecom
17 ; 208 25 001134 ; France ; LycaMobile ; LycaMobile
18 ; 208 20 171275 ; France ; Bouygues ; Bouygues Telecom
19 ; 208 20 031317 ; France ; Bouygues ; Bouygues Telecom
20 ; 208 20 154456 ; France ; Bouygues ; Bouygues Telecom
21 ; 208 20 144857 ; France ; Bouygues ; Bouygues Telecom
22 ; 208 20 031261 ; France ; Bouygues ; Bouygues Telecom
23 ; 208 20 144819 ; France ; Bouygues ; Bouygues Telecom
24 ; 208 20 100230 ; France ; Bouygues ; Bouygues Telecom
```

```
Terminal 2
Fichier  Édition  Affichage  Rechercher  Terminal  Aide
$ airprobe_rtlsdr.py
linux; GNU C++ version 5.3.1 20151219; Boost_105800; UHD_003.009.002-0-unknown

gr-osmosdr 0.1.4 (0.1.4) gnuradio 3.7.9
built-in source types: file osmosdr fcd rtl rtl_tcp uhd miri hackrf bladerf rfspace
ace airspy redpitaya
Using device #0 Realtek RTL2838UHIDIR SN: 00000001
Found Rafael Micro R820T tuner
[R82XX] PLL not locked!
Exact sample rate is: 2000000,052982 Hz
[R82XX] PLL not locked!
Using Volk machine: sse3_64_orc
2d 06 22 00 d8 58 3a 30 a0 0d 25 b8 2b 2b 2b 2b 2b 2b 2b 2b 2b 2b 2b 2b 2b 2b 2b
31 06 21 00 08 29 43 02 37 10 34 2b 2b 2b 2b 2b 2b 2b 2b 2b 2b 2b 2b 2b 2b
15 06 21 00 01 f0 2b 2b 2b 2b 2b 2b 2b 2b 2b 2b 2b 2b 2b 2b 2b 2b 2b 2b 2b 2b
2d 06 22 00 ec 58 13 18 80 06 e3 b9 2b 2b 2b 2b 2b 2b 2b 2b 2b 2b 2b 2b 2b 2b
15 06 21 00 01 f0 2b 2b 2b 2b 2b 2b 2b 2b 2b 2b 2b 2b 2b 2b 2b 2b 2b 2b 2b 2b
15 06 21 00 01 f0 2b 2b 2b 2b 2b 2b 2b 2b 2b 2b 2b 2b 2b 2b 2b 2b 2b 2b 2b 2b
59 06 1a 8f e7 90 80 ad 1c 60 49 00 00 00 00 00 00 00 00 00 00 ff 79 00 00
01 2b 2b 2b 2b 2b 2b 2b 2b 2b 2b 2b 2b 2b 2b 2b 2b 2b 2b 2b 2b 2b 2b 2b 2b
2d 06 22 00 90 0e 42 fa cf 58 e5 08 2b 2b 2b 2b 2b 2b 2b 2b 2b 2b 2b 2b 2b 2b
59 06 21 00 08 29 80 02 51 34 80 17 08 29 80 02 20 69 66 2b 2b 2b 2b 2b 2b
25 06 21 00 05 f4 d1 68 9f 28 23 2b 2b 2b 2b 2b 2b 2b 2b 2b 2b 2b 2b 2b 2b 2b
25 06 21 00 05 f4 ff 68 0f 60 23 2b 2b 2b 2b 2b 2b 2b 2b 2b 2b 2b 2b 2b 2b 2b
```

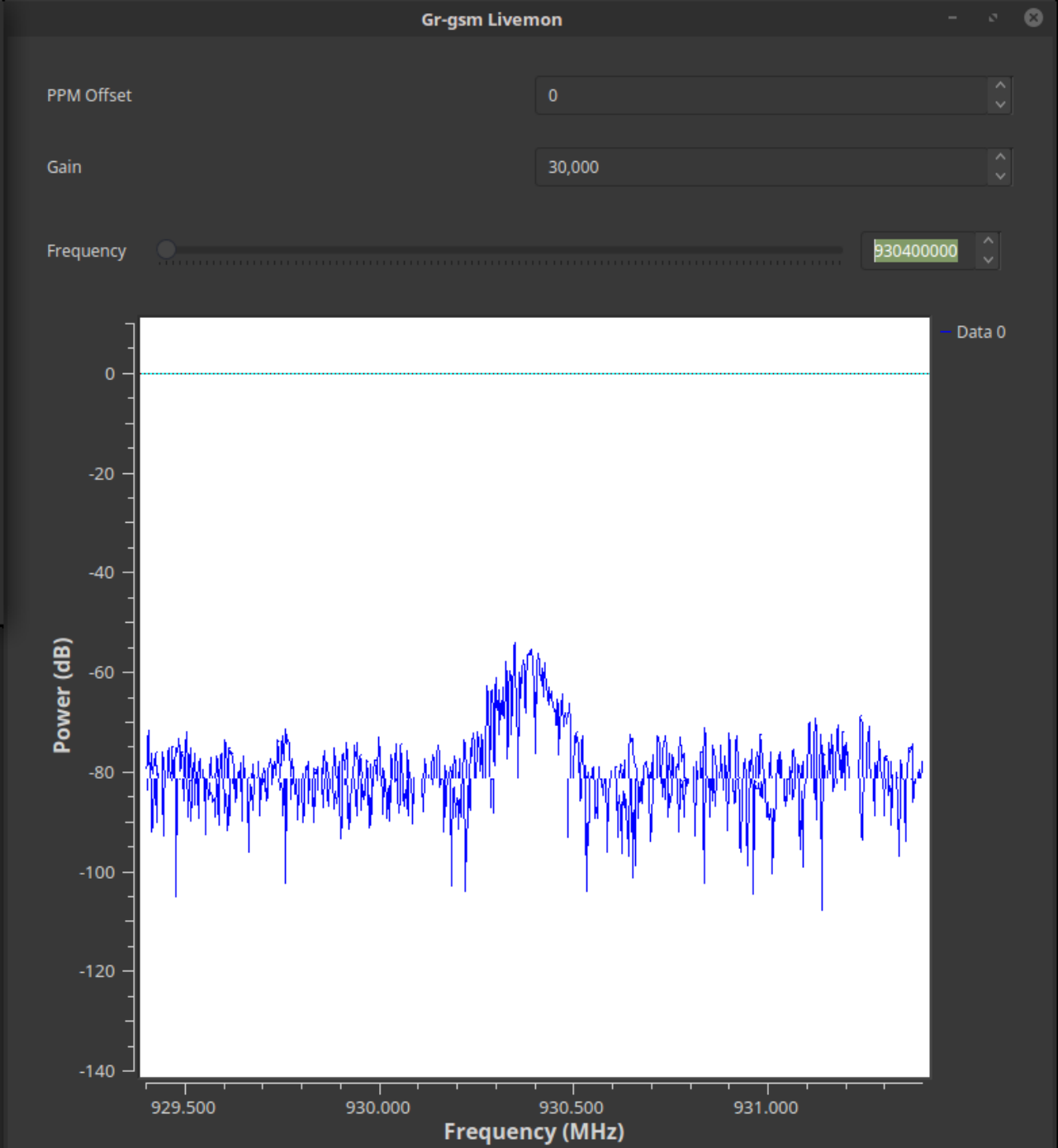

Source: <https://goo.gl/5L29Ft>



IMSI Catchers in Practice

User identification

- Retrieve IMSI / IMEI / TMSI
- Reject location update (ME connects to real network)
- Tracking

Traffic Man-in-the-middle

- Hold user in cell
- Actively intercept traffic
 - Relay to real network
 - Active or passive decryption

UMTS Downgrade

- Blocking UMTS transmission
- Spoofing system messages

Hold but intercept passively

- Imprison in cell
 - Phone not lost to neighbor cell

Fake Base Stations

Dirtboxes on a Plane

How the Justice Department spies from the sky

1 Planes equipped with fake cellphone-tower devices or 'dirtboxes' can scan thousands of cellphones looking for a suspect.

2 Non-suspects' cellphones are 'let go' and the dirtbox focuses on gathering information from the target.

3 The plane moves to another position to detect signal strength and location...

4 ...the dirtbox will 'let go' of the suspect's phone once officers move into position nearby. Those officers then use their handheld device to connect to the phone and zero in on the suspect.

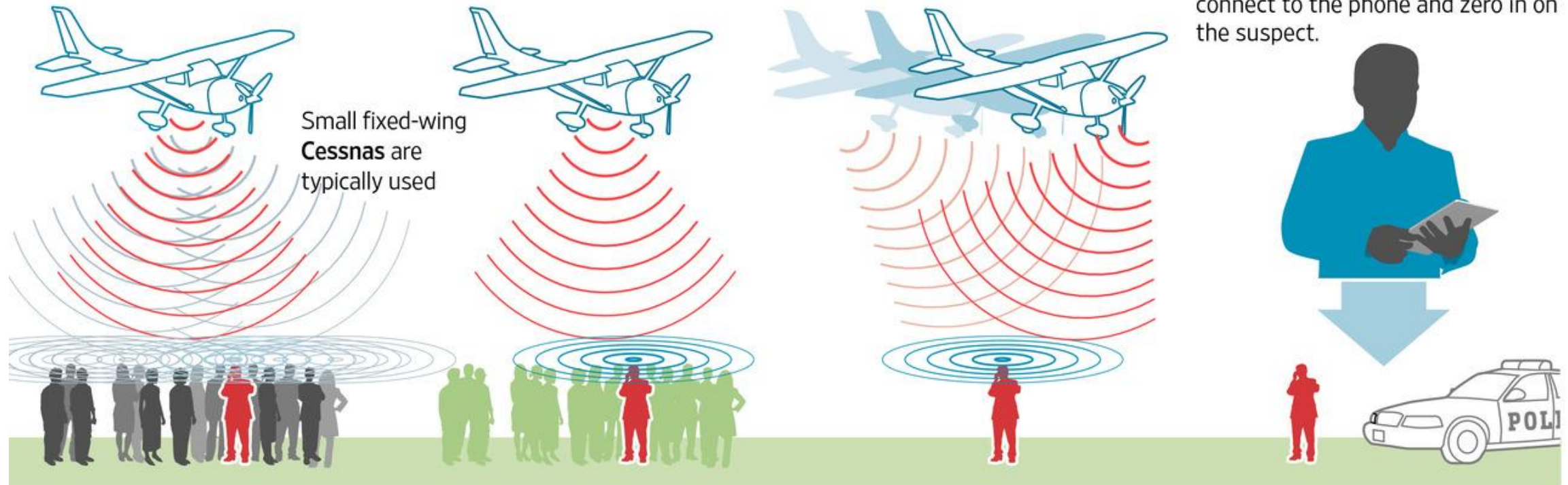

Source: people familiar with the operations of the program

Source: <https://goo.gl/C2GUCK>

Brian McGill/THE WALL STREET JOURNAL.

Active Attack: DoS

Fake base station sending messages

- „You are an illegal cellphone“
- „No network available here. You can shut down your 2G/3G/4G modem.“

Attach Request message
can include cause for
reject
→ Some special causes
result in no service...

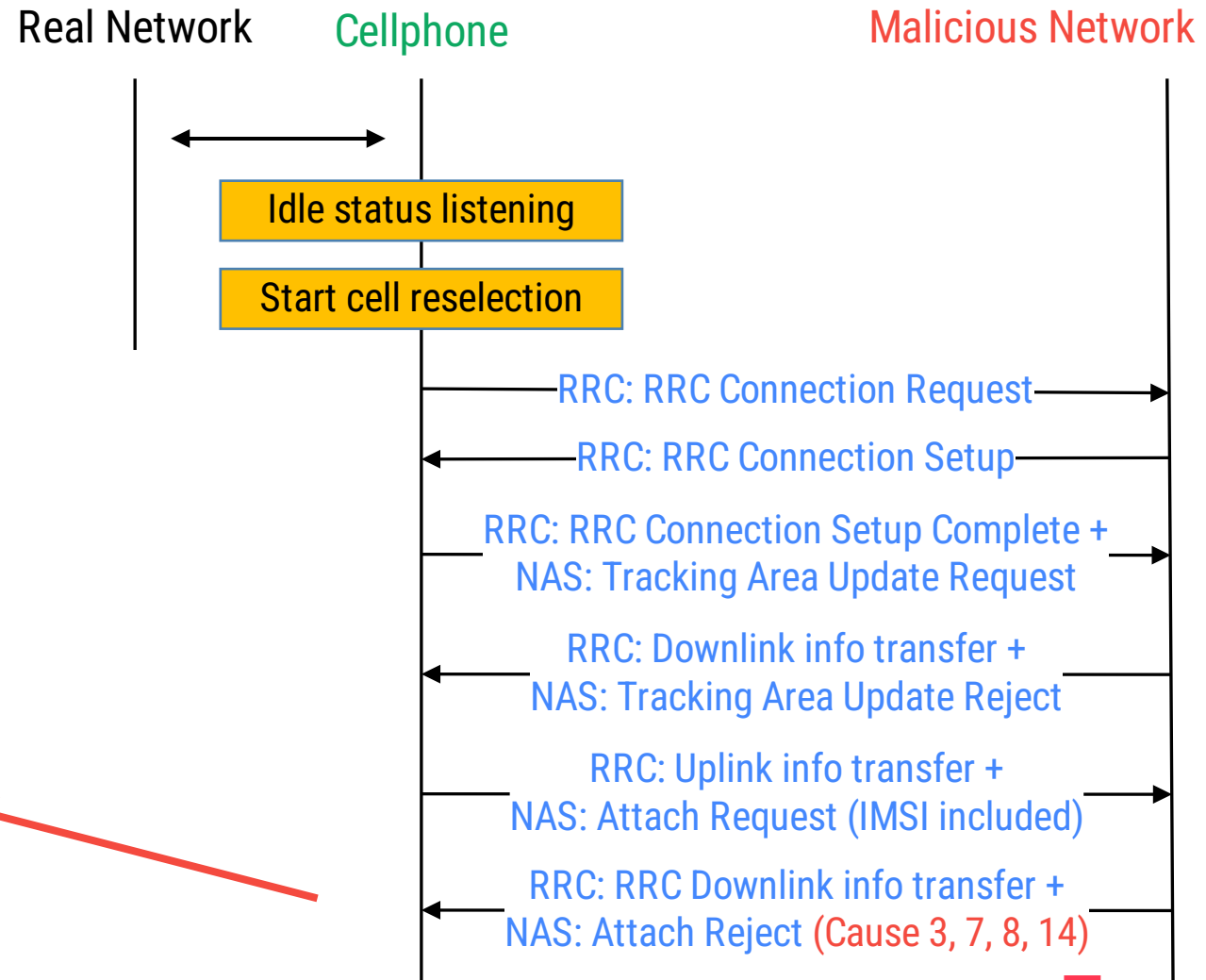

Passive Attack: Key Cracking

- A5/1 vulnerable to generic pre-computation attacks
 - Goal: Break session key for communication between base station and phone

How to?

1. Intercept GSM call with reprogrammed 20 euro phone
 - Idea: Cluster multiple phones for wide-scale capture
2. Crack A5/1 session key using rainbow tables (1-2 TB)
 - Done in a few seconds using GPU power

Note: Also A5/3 uses only 64 bit key on SIM & USIM

→ According to „Intercept“ broken by NSA Source: <https://goo.gl/mPluNH>

→ GSM A5/4 and UMTS UEA/1 considered secure with USIM (128 bit key)



Signaling System 7

- Protocols used by most Telcos to identify network elements, clients, ...
- Share session key in case of **roaming** (but works also without roaming!)

Problem:

- Walled-garden approach → we trust each other, need no auth
- Getting access is easy
 - Buy from telcos for < 1000 euro / month
 - Find equipment unsecured on internet (Shodan)

Attacker's playground

- Track any phone using a variety of signaling messages, e.g.
 - Phone number → AnytimeInterrogation → Get subscriber location (Cell ID)

Signaling System 7

Send from any international SS7 inter-connection → abuse legitimate messages

Abuse Scenarios Allow Obtaining Authentication Data

- Local passive intercept: `SendIdentification`
 - Normally only used internally between MSCs
 - Easily blockable at network boundary
- 3G IMSI catcher: `SendAuthenticationInfo`
 - Legitimately used for roaming, hard to prevent misuse
- Rerouting attacks: `UpdateLocation`
 - Eg receive call instead of victim

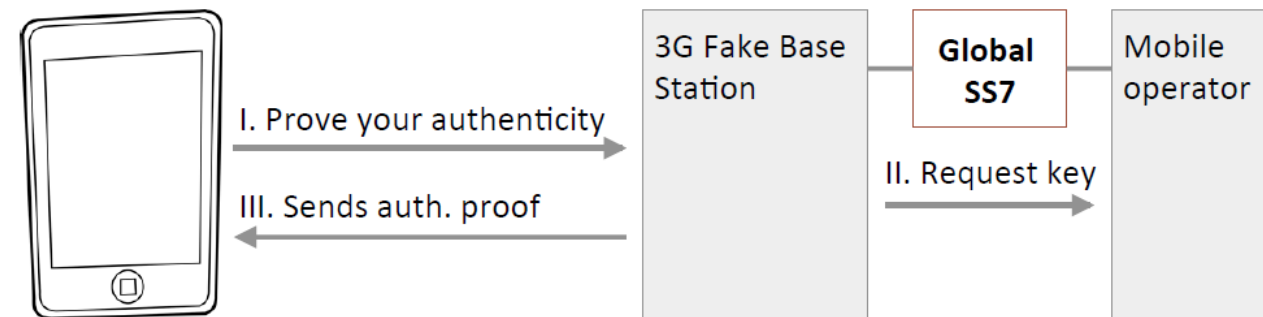
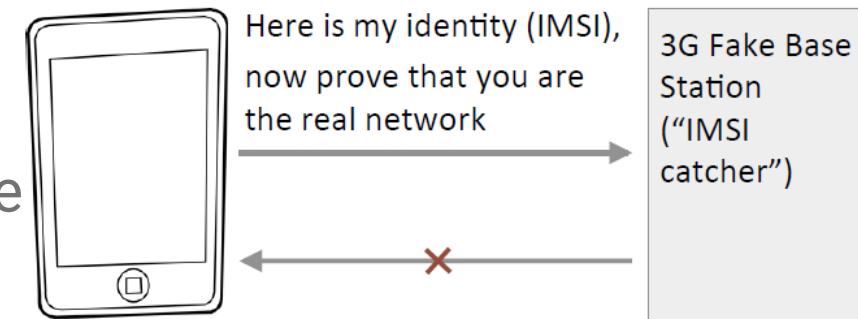





Signaling System 7

How to passively intercept 3G (A5/3)?

1. Use software-defined radio (SDR) to capture 3G transactions
2. Query SS7 SendIdentification to get decryption key

Note: For many networks no SS7 needed for 3G interception!

Network	Encrypts	Authenticates calls / SMS	Protects integrity
	X	X	✓
	X	X	✓
	X	X	✓
	X	X	✓
	X	X	✓

Source: <https://goo.gl/YBhvXw>

LTE Security

Cipher & USIM improvements

→ No known ways to break used crypto, recover key from SIM, break authentication, encryption, or integrity protection

But...

- Not everything is encrypted
 - E.g. null encryption supported → Data is simply (unencrypted) plaintext
- Several messages allowed without integrity protection
 - E.g. null integrity for emergency calls, broadcast system, cell handover

Low-cost IMSI catcher for 4G/LTE networks tracks phones' precise locations

\$1,400 device can track users for days with little indication anything is amiss.



The attacks target the **LTE specification**, which is expected to have a user base of about 1.37 billion people by the end of the year, and require about \$1,400 worth of hardware that run freely available open source software. The equipment can cause all LTE-compliant phones to leak their location to within a 32- to 64-foot (about 10 to 20 meter) radius and in some cases their GPS coordinates,

Source: <http://goo.gl/jlD7jQ>

What?

Exploiting LTE *specification* flaws

Problems?

- RRC Protocol
 - Measurement reports for handover
 - **Not authenticated, not encrypted**
- EMM Protocol
 - Control device mobility
 - **Not integrity protected**

Attacker can

- Track user location / movements
- Downgrade to non-LTE

LimeSDR: Flexible, Next-generation, Open Source Software Defined Radio

[Home](#) [Updates](#) **40** [Backers](#) [History](#)

Source: <https://goo.gl/SD2ouo>

\$773,527 raised
of \$500,000 goal

Funded!

Order Now

Jun 21
funded on

154%
funded

3,175
pledges



02:41

HD

LimeSDR

\$289

The LimeSDR is based on Lime Microsystem's latest generation of field programmable RF transceiver technology, combined with FPGA and microcontroller chipsets. These connect to a computer via USB3. LimeSDR then delivers the wireless data and the CPU provides the computing power required to process the incoming signals, and to generate the data to be transmitted by the LimeSDR to all other devices.

Use with popular open source LTE projects

- OpenLTE See: <https://goo.gl/GEUeHV>
- Open Air Interface See: <https://goo.gl/qSNrxk>

Other Attack Vectors

- Supply Chains
 - Network Infrastructure
 - Baseband
- (U)SIM cards
 - Cracking SIM update keys, deploy SIM malware
- Radio / IP access network
 - Radio access network
 - IP access (GGSN, Routers, GRX)

See: <https://goo.gl/WYxUTq>





Protection Mechanisms

Measures in Austria

- Numbers from 2014 (no LTE!)
- All 3G networks use A5/3 encryption
- Unclear if networks would accept unencrypted transactions as well (subscriber-initiated)
- Call/SMS impersonation possible in all 2G networks
 - Using cracked/leaked K_C

Attack vector	Networks			
	A1	T-Mobile	Three	
2G Over-the-air protection				
- Encryption algorithm	A5/0	1%	0%	0%
	A5/1	8%	31%	35%
	A5/3	91%	69%	65%
- Require IMEI in CMC				
- Hopping entropy				
- Authenticate calls (MO)		21%	23%	14%
- Authenticate SMS (MO)		9%	67%	10%
- Authenticate paging (MT)		11%	16%	16%
- Authenticate LURs		40%	44%	61%
- Encrypt LURs		100%	100%	100%
- Update TMSI		32%	81%	44%
3G Over-the-air protection				
- Encryption				
- Update TMSI		1%	61%	1%
HLR/VLR configuration				
- Mask MSC				
- Mask IMSI				

Abuse often detectable!

	Attack scenario	Detection heuristic
 <p>SMS Attacks SS7 Attacks</p>	<ul style="list-style-type: none">▪ SIM OTA attacks▪ Semi-lawful Tracking through silent SMS▪ SS7 abuse: Tracking, Intercept, etc.	<ul style="list-style-type: none">▪ Unsolicited binary SMS▪ Silent SMS▪ Empty paging
 <p>IMSI Catcher</p>	<ul style="list-style-type: none">▪ Tracking or Intercept through 2G or 3G fake base station	<ul style="list-style-type: none">▪ Unusual cell configuration and cell behavior (detailed later in this chapter)
 <p>Network Security</p>	<ul style="list-style-type: none">▪ Insufficient encryption leads to Intercept and Impersonation▪ Lack of TMSI updates enables Tracking	<ul style="list-style-type: none">▪ Encryption level and key change frequency▪ TMSI update frequency

SnoopSnitch

Collect network traces on Android → analyze for abuse

Features

- Detection of fake base station (IMSI catcher)
 - Suspicious cell configuration / behaviour
- User tracking
- SS7 attacks

Requirements

- Rooted phone with Android ≥ 4.1
- Qualcomm chipset
 - Samsung Galaxy S4/S5, Sony Z1, OnePlus 2, ...

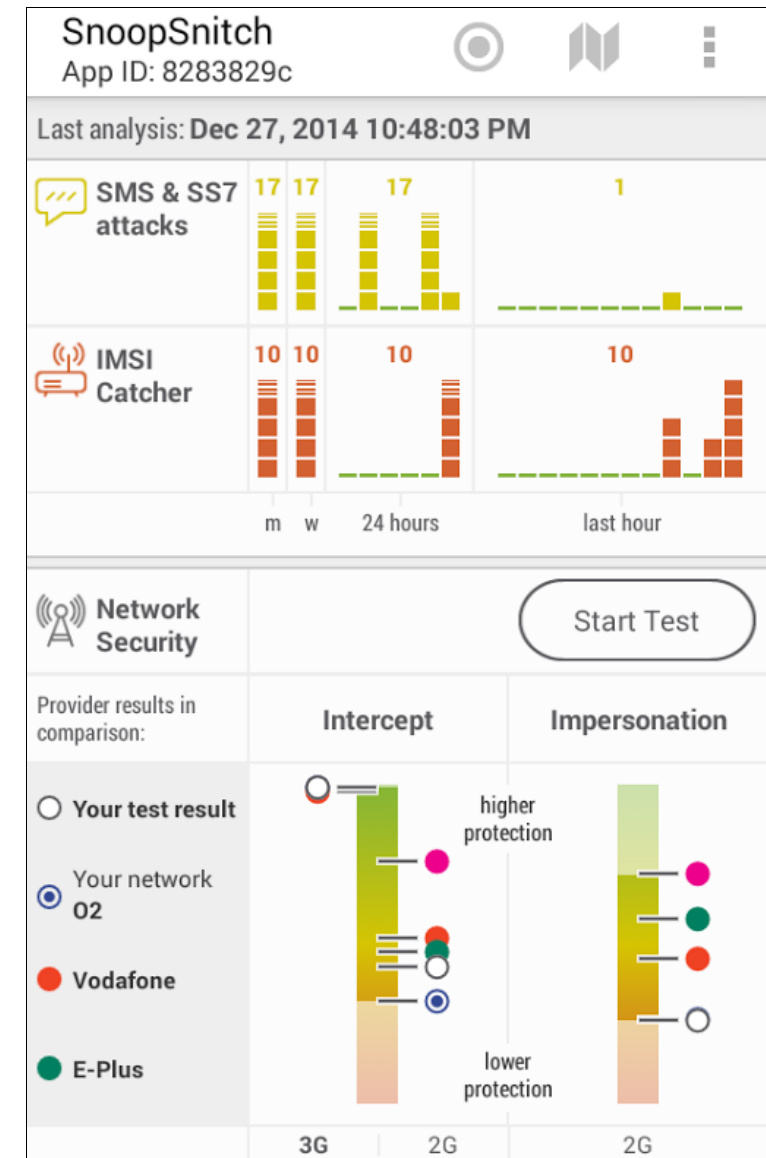

Source: <https://goo.gl/KlhaZa>

AIMSICD

Features

- Focus: Detecting IMSI catchers
- Check consistency of
 - Tower information
 - LAC / Cell ID
 - Signal strength
- Detect silent SMS (type 0 messages)
- Detect FemtoCells

Requirements

- Rooted Android
- Ability to send AT commands to modem

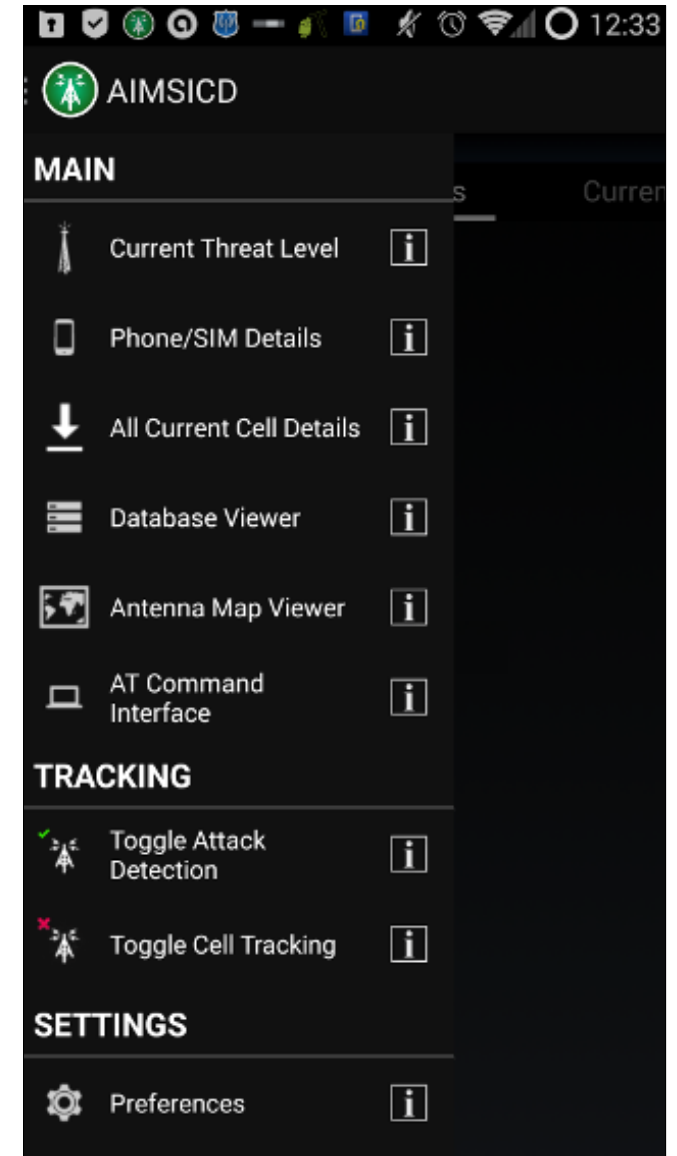

Source: <https://goo.gl/mbZFgE>

Network Protection Status

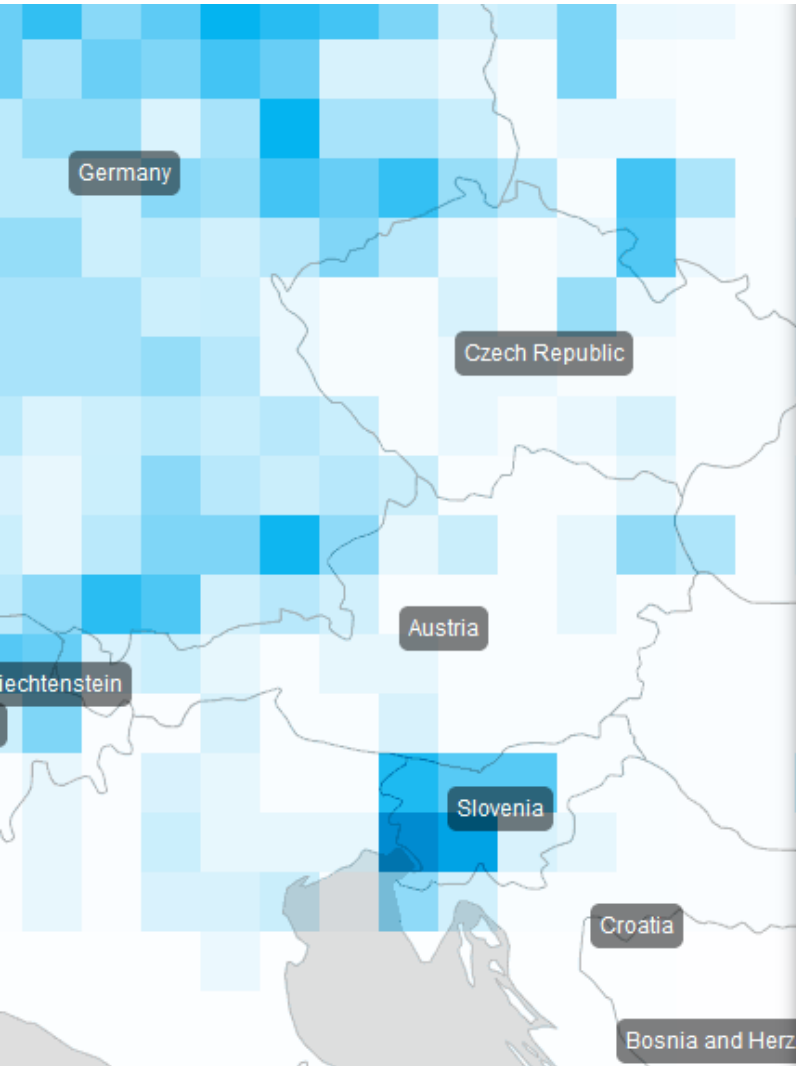

Austria [Country report \(2019-08\)](#)



- A1**
- T-Mobile**
- Three**

- Intercept
- Impersonation**
- Tracking
- USIM prevalence

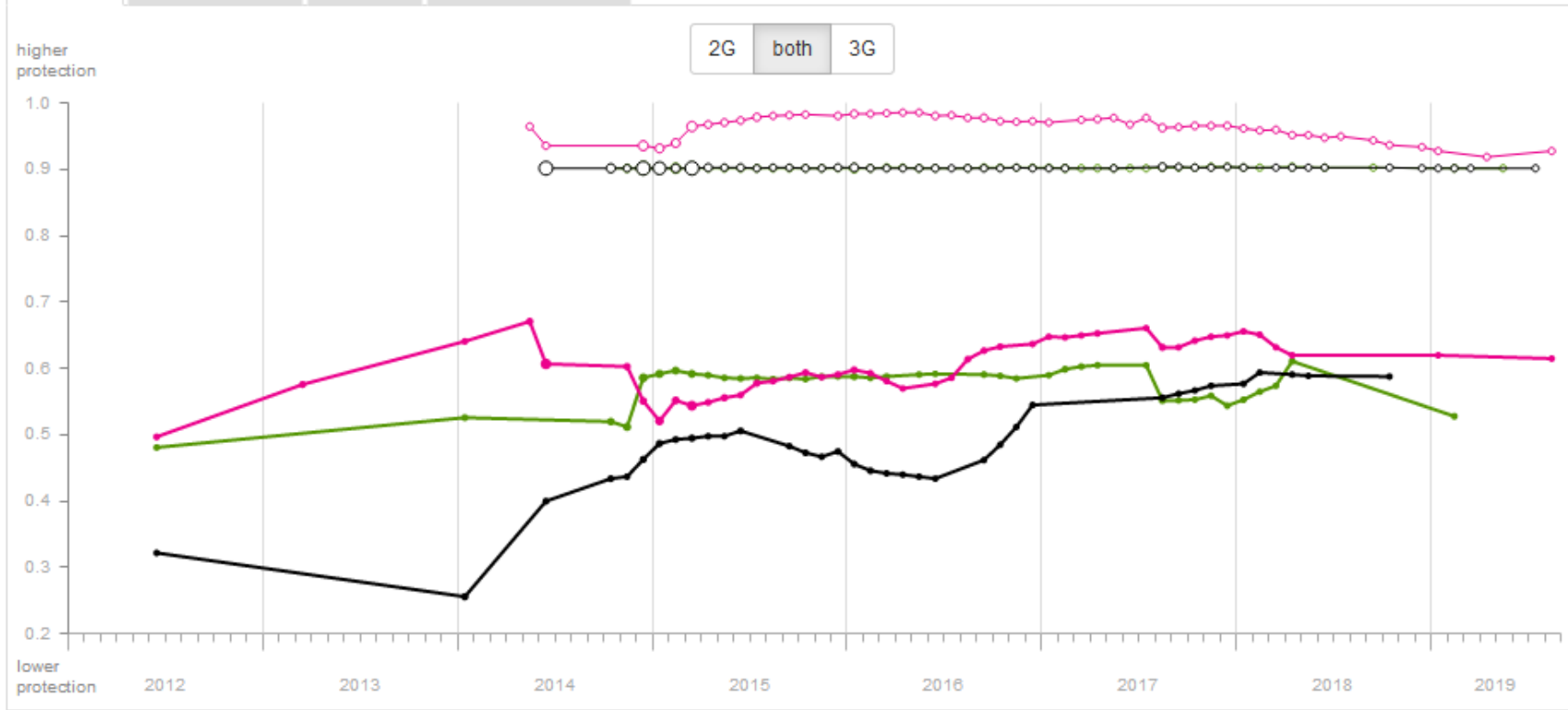

Source: <http://gsmmap.org>

Physical Cell Locations

Tipp: Um Standorte in Ihrer Umgebung zu finden geben Sie im Feld "Adresse, Ort oder PLZ" die Postleitzahl bzw. den Namen der gesuchten Gemeinde ein und klicken Sie anschließend auf die Taste "Suchen".

Allgemeine Daten

Standortanfrage versenden	
Funkdienst	Mobilfunk
Trägerstruktur	Mast
Gemeinsame Nutzung (Sharing)	Nein

Station1

Protokoll(e)	GSM, UMTS, LTE, 5G
Sendeleistung	380-400 W

Mehr Informationen finden Sie im Kapitel **Erläuterungen** und **Technik**

M 1 : 11.520

© 2020 HERE, © 2020 Microsoft Corporation, © OpenStreetMap Terms

Physical Cell Locations

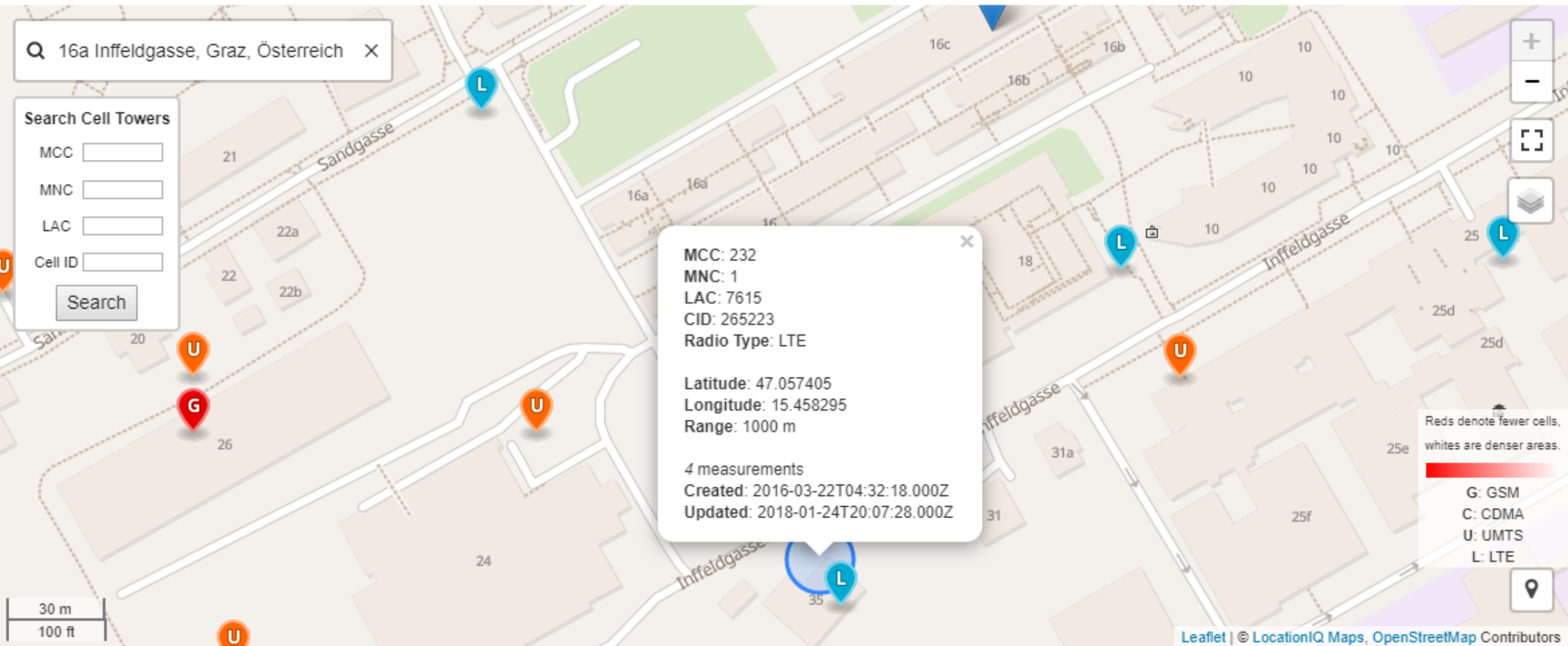

Source: <https://opencellid.org>

Outlook



- 29.05.2026
 - Guest Talk: Georg Löffelmann, Head of Department Mobile, A1 Telekom

- 05.06.2026
 - Mobile Hardware Security